



DC Applications Transient Voltage Filters

RDS

Specifications

Electrical

Input Voltage: Up to 500VDC

Resistance: 10 to 680 ohms, $\pm 10\%$, 0.5 watt

Diode: 1 Amp @ 400 or 1,000PIV

Varistors:

Voltage Code	Max. Allowable DC Voltage	Max. Clamping Voltage	Energy (Joules)
1	170VDC	340V @ 10A	10
3	320VDC	650V @ 10A	17
7	200VDC	395V @ 25A	25

Reverse Leakage Current: <50 microamps

Physical

Termination: #18

Stranded Wire Leads or
#20 Solid Wire Leads

Packaging: Epoxy Filled

Weight: 1 Oz.

Ambient Temperatures

Operating: -40°C to 85°C

Storage: -40°C to 85°C



Ordering Information

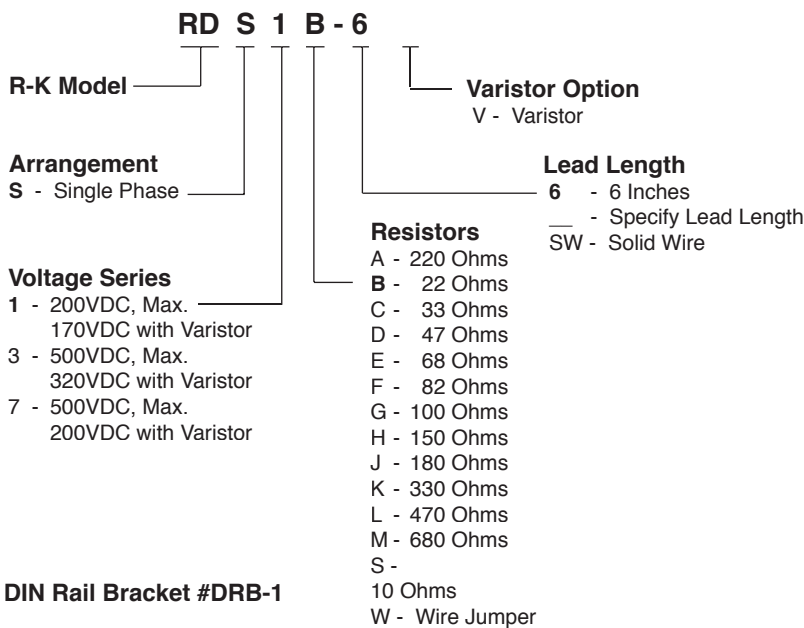

- Up to 170 to 500 Volt Ratings
- DC Applications
- Varistor Options
- Stranded Wire or Solid Wire Leads

Operation

Transient Voltage Filters

R-D networks (Resistance-Diode) are applied to circuits where transient electrical voltages can cause a malfunction or damage in solid state controls or control systems (PLCs, CNCs, NCs, Solid State Counters, etc.). The RDSs are applied in parallel with DC (Direct Current) coils to absorb the transients generated when the coils are de-energized.

Connections

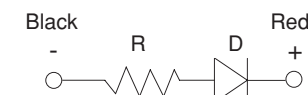

Without Varistor

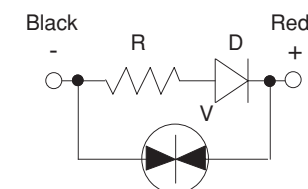

With Varistor

Hook-Up Example

MS = Motor Starter SV = Solenoid Valve

C1 = Contact C2 = Contact

RDS = R-D Network

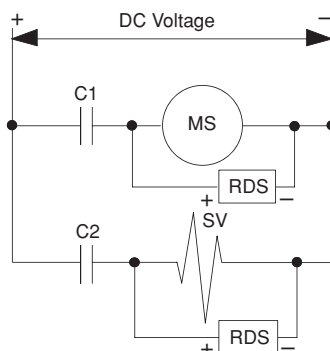

Dimensions

